

No. 637,769.

Patented Nov. 28, 1899.

E. EARLE.
COMPOUND REST FOR ENGINE LATHES, &c.

(Application filed Aug. 2, 1899.)

(No Model.)

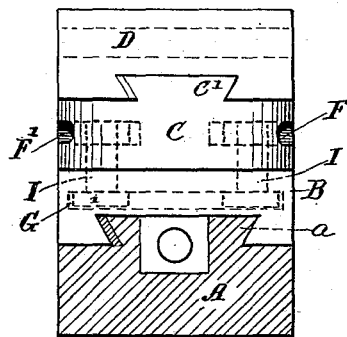
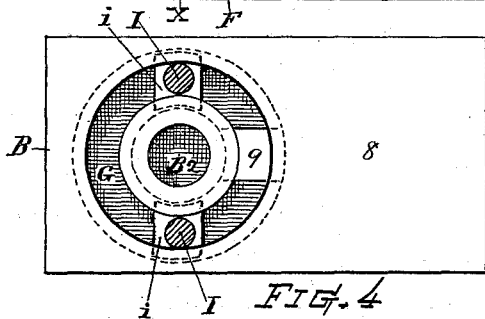
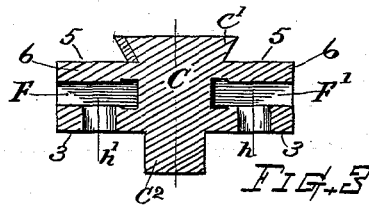
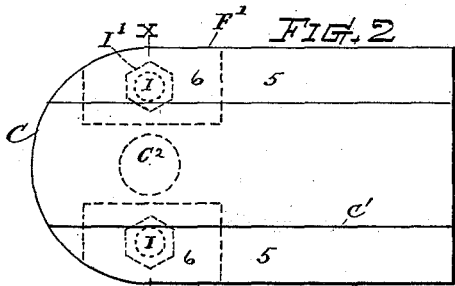
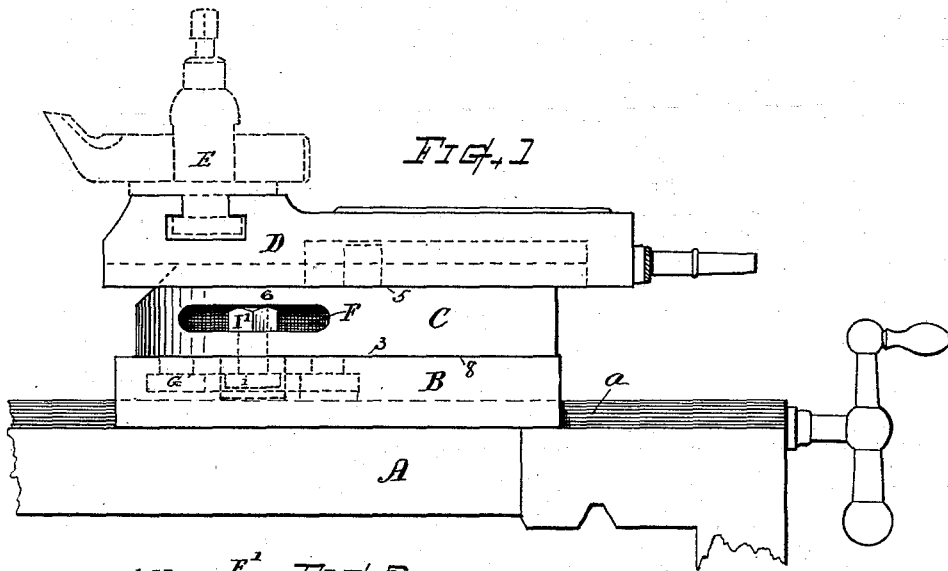

FIG. 5

Witnesses.

W.E. Birch
Simon & King

Inventor.

Enoch Earle
By Chas. H. Durlough
Attorney.

UNITED STATES PATENT OFFICE.

ENOCH EARLE, OF WORCESTER, MASSACHUSETTS.

COMPOUND REST FOR ENGINE-LATHES, &c.

SPECIFICATION forming part of Letters Patent No. 637,769, dated November 28, 1899.

Application filed August 2, 1899. Serial No. 725,828. (No model.)

To all whom it may concern:

Be it known that I, ENOCH EARLE, a citizen of the United States, residing at Worcester, in the county of Worcester and State of Massachusetts, have invented a new and useful Compound Rest for Engine-Lathes, &c., of which the following, together with the accompanying drawings, is a specification sufficiently full, clear, and exact to enable persons skilled in the art to which this invention appertains to make and use the same.

My present invention relates to an improvement in the construction of the swivel-plate and the manner of combining the same with the base and top block; and it consists in a compound rest for the purposes set forth having a laterally-chambered swivel and wherein the parts are formed and arranged as hereinafter specified, the object being to attain a firm, full, and unyielding bearing for the tool-block, a solid structure with comparatively diminished width of base; also, to render the appliance highly efficient, clean, and convenient for practical use and adapted for working in close proximity to the lathe-head or adjacent to a second compound rest when, as frequently occurs, it is desired to employ a plurality of tool-carriers on the same machine.

In the drawings, Figure 1 represents a side view of a compound rest embodying my invention. Fig. 2 is a top view of the swivel separately. Fig. 3 is a transverse vertical section of the swivel. Fig. 4 represents the top of the base-piece, and Fig. 5 a rear end elevation.

Referring to parts, A denotes the usual carriage, which is supported on the body of the lathe (not shown) and operated in well-known manner.

B indicates the base-piece of the compound, which slides on the dovetailed way *a* upon the carriage.

C indicates my improved swivel or swivel-plate, and D is the top-block, which carries the tool post or puppet E and is mounted to slide on the dovetailed way *c'* upon the top of the swivel, as indicated. The swivel C in accordance with my invention is constructed, as shown, with lateral inwardly-extending recesses or chambers F and F', formed in the opposite sides thereof between the bottom

seating-surfaces 3 and the top bearing-surfaces 5, which latter surfaces horizontally flank the raised centrally-disposed dovetailed guideway C' and sustain the longitudinally-adjustable top block D, that is gibbed under said dovetail and is slidably supported upon said bearing-surfaces 5, which are made complete or without cut-away edges, but extend the entire length of the swivel in full unbroken width and with a sustaining body of metal at 6, bridging over the underlying cavity or recess and affording thereover an equally firm bearing for the block D, as at other portions of the surface 5. The upper and lower interior surfaces of the recesses F F' are parallel with each other and with the top and bottom bearing-surfaces 3 and 5, the recess-cavities being best cut out by the aid of a rotating milling-tool entered endwise into the edge of the swivel-plate and then fed horizontally therein for the required length of chamber. Holes *h h'* are formed from the chambers downward.

The under surface 3 of the swivel is made flat and plain to seat and swing upon the base B and is provided with a small integral pintle projection C², that fits into a circular cavity B² in the base and forms the swiveling-axis about which the parts C and D swing. The base B is made with flat top surface 8 and solid body with straight parallel edges corresponding to the width of the swivel C and top block D, and an annular undercut groove G of small diameter is formed in the top surface 8 of said base concentrically around the axis-cavity B², a hole 9 being provided for the introduction thereto of the bolt-heads *i*. The clamp-bolts I are disposed with their heads *i* in the groove G and their nuts I' embraced within the recesses F and F', interjacent to the upper and under surfaces thereof. Said nuts can be turned by introducing a suitable wrench laterally into the recess. The nuts are embraced top and bottom between the parallel surfaces within the recesses.

Among the advantageous results attained by my improvement may be mentioned the following: A compound with full width of block and comparatively narrow base is produced which can be brought closely adjacent to a lathe-head or to another compound

in cases where it is desired to employ a plurality of tools simultaneously on the same machine. The nuts and bolts being placed in the recesses, tools can be supported near the work, no outside lugs being necessary, as in the ordinary construction. The surfaces have full uniform width, their edges not being cut away for the nuts and bolts, and the top block or tool-carrier has a full continuous bearing, hence thereby making the support of the same very rigid and substantial. The nuts and bolts are out of the way from any interference and are protected from chips and dirt falling and depositing thereon and from accumulation of oil or grease from the block-bearing surfaces, as frequently occurs with the usual structure of compounds.

It will be understood that I do not herein claim the connection, broadly, of a base and swivel in a compound by means of clamp-bolts the heads of which are retained in a circular groove. Neither do I claim the arrangement and means of operating the top block upon the swivel.

What I claim as my invention, and desire to secure by Letters Patent, is—

1. In a compound rest for engine-lathes, an axially-pivoted swivel C provided with lateral inwardly-extending recesses F and F', respectively disposed in the sides thereof opposite the axial center, with the overbridging

metal at 6, and full continuous bearing-surfaces 5; in combination, with the longitudinally-movable tool-supporting block D mounted on said swivel, the base-piece B supporting the pintle or axial center, and swiveling clamp devices uniting said base-piece and swivel at opposite sides of the axis inside the parallel side lines of the swivel-body, and accessible for operating within said recesses, all substantially as set forth.

2. In a compound rest for engine-lathes; the swivel having parallel bearing-surfaces, its side edges provided with opposite inwardly-extending recesses with parallel interior surfaces, underlying said bearing-surfaces, with an overbridging portion of metal between, and having the rigid cylindrical axial pintle, as shown; in combination with the straight parallel edged base-piece provided with the central cylindrical cavity, and the annular undercut groove concentric therewith, and clamp-bolts disposed between said swivel and base, with their nuts embraced between the upper and lower inner surfaces of said recesses, all substantially as shown and described.

Witness my hand this 31st day of July, 1899.

ENOCH EARLE.

Witnesses:

CHAS. H. BURLEIGH,
CHARLES S. BACON.